



# Installation and operating instructions



## Water level controller and limiter

BA 14

RBA 24

RBA 34



D-07-B-16636-EN-0.doc

Ausgabe 07/2016

## - ⓘ Table of contents-

<b>1.</b>	<b>Health and safety instructions</b>	<b>4</b>
1.1	General health and safety instructions.....	4
1.2	Unit-specific safety instructions .....	5
1.3	Exclusion of liability .....	5
<b>2.</b>	<b>Important information</b>	<b>6</b>
2.1	Intended use .....	6
<b>3.</b>	<b>Explanations</b>	<b>6</b>
3.1	Scope of supply .....	6
3.2	System description .....	6
3.3	Function .....	6
<b>4.</b>	<b>Technical data</b>	<b>7</b>
4.1	Versions .....	7
4.2	Type of connection .....	8
4.3	Materials .....	8
4.4	Application limits .....	8
4.5	Corrosion resistance .....	8
4.6	Identification plate / Marking .....	8
<b>5.</b>	<b>Construction</b>	<b>9</b>
<b>6.</b>	<b>Assembly</b>	<b>10</b>
6.1	Version with flange .....	10
6.2	Version with welding end.....	10
6.3	Heat treatment of weldseams .....	10
6.4	Drain piping.....	10
<b>7.</b>	<b>Electrical connection .....</b>	<b>11</b>
7.1	Wiring diagram .....	11
7.2	Connection magnetic switch.....	12
7.3	Technical data magnetic switch .....	12
<b>8.</b>	<b>Commissioning</b>	<b>12</b>
8.1	Commissioning of unit together with the boiler.....	12
8.2	Commissioning of unit if boiler is already in operating condition.....	13
<b>9.</b>	<b>Operation monitoring</b>	<b>13</b>
9.1	Purging of connection lines .....	13
9.2	Function test.....	13
<b>10.</b>	<b>Maintenance</b>	<b>14</b>
10.1	Opening of standpipe .....	14
10.2	Closing of standpipe.....	14
10.3	Exchange of float device.....	14
10.4	Tightening torques.....	15

<b>11.</b>	<b>Drain valve</b>	<b>16</b>
11.1	Construction .....	16
11.2	Assembly.....	17
11.3	Commissioning.....	17
11.4	Maintenance .....	17
<b>13.</b>	<b>Spare parts</b>	<b>19</b>
13.1	Float switch .....	19
13.2	Drain valve .....	19
<b>14.</b>	<b>Decommissioning</b>	<b>20</b>
14.1	Disposal .....	20
<b>15.</b>	<b>Declaration of Conformity</b>	<b>21</b>
<b>16.</b>	<b>Supplement</b>	<b>22</b>
	Warranty .....	22



# Safety instructions



## General health and safety instructions

### 1. Avoidance of danger for persons and property

- Only use unit for intended purpose.
- No additional mountings and modifications on the unit without our approval.
- Adhere to the standards for prevention of accidents and to the plant specific safety regulations.
- Read and observe installation and operating instructions.

### 2. Application limits

Only use this unit according to these operating instructions and to the parameters agreed upon in the delivery contract (see identification plate) including the agreed operating conditions.

### 3. Avoidance of danger and damages

- Distribute these mounting and operating instructions to appropriate department "arrival of goods, works transport, mounting, commissioning and maintenance".
- When passing the unit to a third party, these mounting and operating instructions must be enclosed in the national language of this third party.
- Only skilled and qualified personnel with special work order may work on the unit, which must be free of pipeline stress!
- Carefully read, observe and preserve these mounting and operating instructions.
- **Observe and adhere to the precautions marked in bold characters in the sections of these mounting and operating instructions!**
- Avoid shocks and impacts during transport, which could damage the unit.
- In case of intermediate storage take care for a dry and appropriate place where the unit cannot be damaged.

### 4. Marking

In these mounting and operating instructions, the safety instructions are specially marked with the following symbols:



Danger

Means danger to life and/or serious property damage in case of non-observance. Never ignore!



Attention

Means that you must pay special attention to the technical relationships.

## Unit-specific safety instructions

- ⇒ The fitting is under pressure during operation!  
If flange connections, screw plugs or stuffing boxes are unfixed, hot water and steam will escape.
- ⇒ Carry out assembly and maintenance works only if plant is completely pressureless!
- ⇒ The fitting is hot during operation!  
Severe burns on hands and arms are possible.  
Wait until the unit has cooled before carrying out assembly and maintenance works!
- ⇒ Severe burns and scaldings on the whole body are possible!
- ⇒ Wait until the unit has cooled. In case of opening and disassembling the unit, residual medium can escape. Further evaporation is also possible on pressureless plant.
- ⇒ Sharp-edged interior parts can cause cutting damages on the hands!  
Always wear work gloves when exchanging packing, valve seat and valve cone!

***Pay attention that the magnetization of the permanent magnets in the unit is not changed! Avoid magnetic fields close to the units!***

## Exclusion of liability

The IGEMA GmbH Mess- und Regelsysteme does not accept liability when a/m regulations, instructions and warning indications are not observed and adhered to. The operator is responsible for modifications on a unit of IGEMA (if they are not explicitly specified in the mounting and operating instructions).  
The magnetic switch may not be opened.  
Each warranty claim expires if the test seal is damaged.



## 2. Important information

### 2.1 Intended use

#### Float switch RBA24/34, BA14:

The float switch type RBA24/34 can be used as two-point water level controller or limiter without special design for steam generators.

The float switch type BA14 can only be used as water level limiter without special design.

The product corresponding to the EU 2014/68/EU.  
Applied standards as per EN 13445 / EN 12952 / EN 12953 / AD 2000 or ASME-Boiler.

Type	EG-component test
BA14	20140804-32636-1890765210-100-421411-EP-BA14
RBA24,34	20140804-32636-1890765210-100-421411-EP-RBA24-34-25-35

## 3. Explanations

### 3.1 Scope of supply

The unit is delivered as complete unit.

### 3.2 System description

The float switch (different versions) is used to control or to limit the level of containers and steam generators.

### 3.3 Function

The unit works according to the physical law of the communicating tubes.

The water level controller or limiter is a float actuated unit where the transmitter magnet connected with the float via the float rod actuates the magnetic switches located inside of the switch housing without direct contact.

## 4. Technical data

### 4.1 Versions

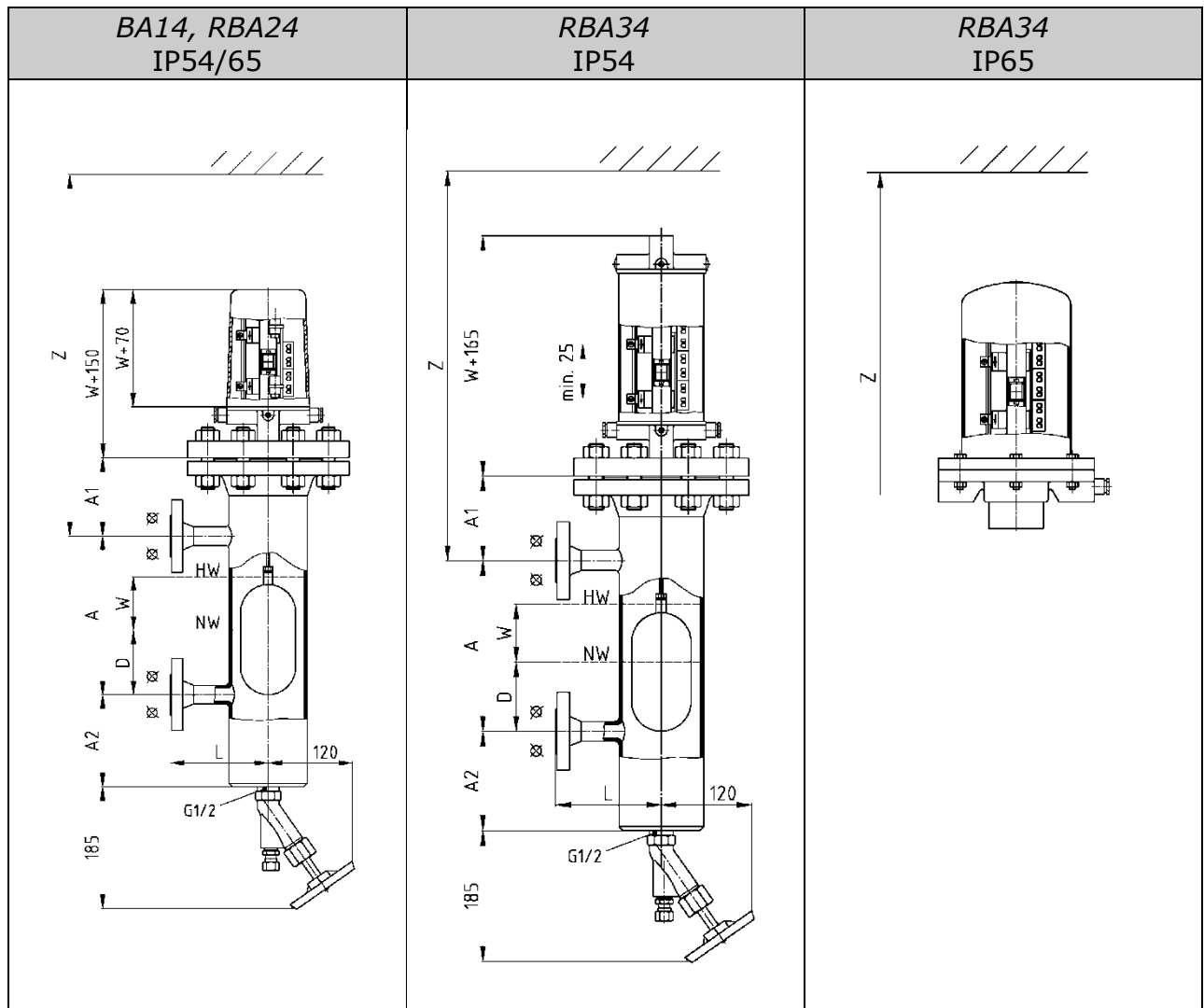

#### Switch ranges:

Range of adjustment	W [mm]								
BA 14	40								
RBA 24		100	150						
RBA 34				250	350	450	550	650	750

#### Dimensions A, Z:

Type	Dim. Z [mm]
BA14, RBA24	A-D+550
RBA34, IP54	A-D+550
RBA34, IP65	A-D+600

but min. 2W+525

Dim. [mm]	A1		A2	
PS [bar]	32	80	32	80
BA14, RBA24/34	112	152	140	

#### Valves:

Valve	Type
Drain valve	AV500, AV520, AV580

## 4.2 Type of connection

Standard : flanges according to DIN or ASME

On request : welding end or Socket Welding according to DIN or ASME

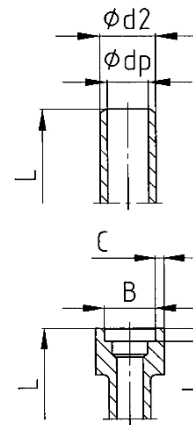

## 4.3 Materials

Components in contact with the medium and pressure-holding components are made of C steel according to DIN or ASME.

## 4.4 Application limits



Max. allowable pressure <b>PS</b>	[bar]	32	50	80
Max. allowable temperature <b>TS</b>	[°C]	239	265	296

## 4.5 Corrosion resistance

The safety of the unit is not influenced by corrosion if it is used as intended.

## 4.6 Identification plate / Marking

The following data are indicated on the identification plate:

 <p>IGEMA GmbH Mess-und Regelsysteme Antwerpenerstraße 1 Germany - 48163 Münster</p> <p><b>CE 0035</b> See installation instructions</p> 	Built	<b>A</b>	Type	<b>B</b>	
	PS	<b>C</b>	bar	TS <b>D</b> °C	
	Conn. Type	PN <b>E</b>	DN <b>F</b>		

\* marking depending on the realization

- A Date of manufacture
- B Type of unit
- C Max. allowable pressure
- D Max. allowable temperature
- E Nominal pressure (not listed)
- F Nominal diameter



## 5. Construction

<b>BA14, RBA24</b>		<b>Legend</b>
IP54	IP65	
		<p>(1) Switch housing            (2) Magnetic switch            (3) Transmitter magnet            (4) Transmitter tube            (5) Thread bolt            (6) Hex nut            (7) Upper part            (8) Sealing ring            (9) Transmitter tube cap            (10) Retaining spring            (11) Float rod            (12) Float            (13) Standpipe            (14) Drain valve            (15) Drain connection            (16) Connection stud            (17) O-ring            (18) O-ring            (19) O-ring</p>
<b>RBA34</b>		
IP54	IP65	

## 6. Assembly



Connect shutoff valves (W+D) only with horizontally orientated spindle; the flow direction "→" on the valves (W+D) has to point out into the direction of the standpipe (13)!

Connect unit free of tension with switch housing (1) turned upwards to the boiler studs equipped with shutoff valves.

Pay attention that the height of the LWL mark on the standpipe of the unit corresponds to the one of the boiler!

### 6.1 Version with flange

- Respect installation position!
- Remove protection caps from connection flanges. Caps only serve as transport protection.
- Ensure that sealing surfaces are clean and undamaged.
- Use sealing material as per EN1514 and screws as per DIN2510 or DIN974 (material 1.7709).
- Mount float switch.

### 6.2 Version with welding end

- Respect installation position!
- Remove protection caps. Caps only serve as transport protection.
- Assembly only with welding process 111 (manual arc welding) and 141 (tungsten inert gas welding).

### 6.3 Heat treatment of weldseams

Supplementary temper tests of weldseams are not required!

### 6.4 Drain piping

- Check connection drain valve (14) / standpipe (13) and re-tighten if necessary.
- Mount drain piping on drain valve (15).



Ensure that drain piping has free outlet to atmosphere and is protected from pressure peaks!

- Close valves.

## 7. Electrical connection



Only skilled and qualified personnel may carry out the electrical connection according to the wiring diagram!

Respect the instructions of the VDE (Association for Electrical, Electronic & Information Technologies) and of the local network operators for the installation to be provided by the customer!

Only use cables that are suitable for the operating range!

Observe the switching time of the magnetic switch when designing a safety circuit. Adhere to basic and reliable safety principles as per DIN EN ISO 13849 for electrical components.

### 7.1 Wiring diagram

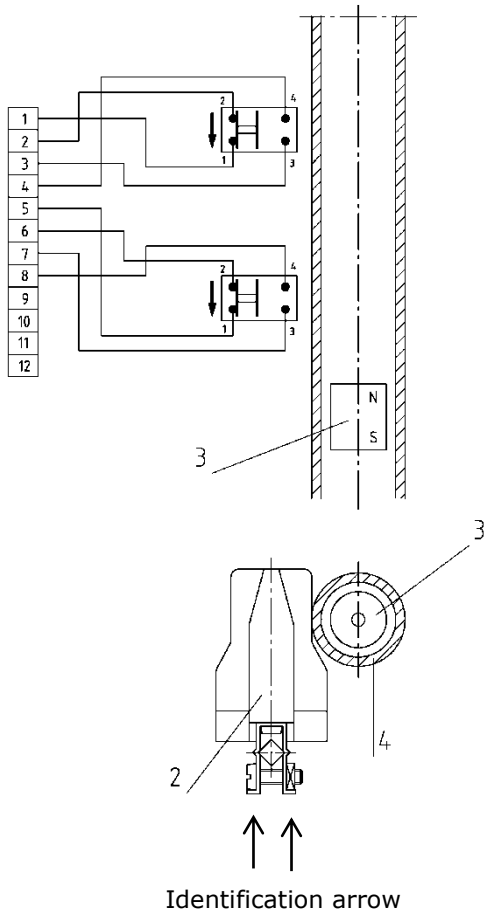

Connection wires:

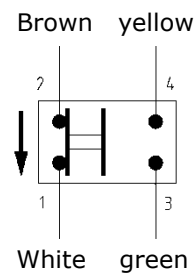

We recommend to use customary RC combinations or a suitable varistor (e.g. 0,1  $\mu\text{F}/100\Omega$ ) as inductive consumer to extend the contact life of the magnetic switch. Resistance value ( $\Omega$ ) and power rating (W) depend on customer indications.

We suggest to use silicon cables free of acetic acid for the further connection cable in the area „connecting housing inside“.

## 7.2 Connection magnetic switch

- Open switch housing (1) and remove foam cushions between transmitter tube (4) and magnetic switch(es) (2).
- The magnetic switches are already rigidly mounted inside of the switch housing and electrically connected to the terminals.  
The magnetic switch can be connected optionally as breaker, maker or change-over contact. Switch base is marked with an arrow.
- If the switch is correctly mounted, the arrow should point downwards.
- Carry out electrical connection.
- Finally ensure that no cable gets in contact with hot elements.

## 7.3 Technical data magnetic switch

Kind of contact	bistable
Contacts	1 breaker / 1 maker
Connection wire	1 x 0,5 mm <sup>2</sup> (16 x ø 0,2) – Cu tinned / PTFE
Wire length L	200 mm
All. ambient temperature	-70°C up to +120°C
Protection	IP68

Type	Switching voltage U	Switching current I	Max. power UxI
M130-KG	≥ 24 VAC	≥ 0,065 A	≥ 1,5 VA
	≤ 24 VDC	≤ 0,6 A	≤ 15 VA
	≤ 24 VDC	≤ 0,008 A	≤ 0,12 VA

Type	Article-No.	Contact material
M130-KG	15-01122	Silver-Palladium AgPd 70/30 massiv, hard-gold plated AuCo 4-6µm

## 8. Commissioning



Beware, the device is hot during commissioning and operation.  
Caution! Danger of scalding!!

### 8.1 Commissioning of unit together with the boiler

*Check specifications of material, pressure and temperature!*

- Close drain valve (14) (see sketch chapter 5).
- Fully open shutoff valves (W+D).
- Check position of magnetic switch (2) in operating condition and adjust the height if necessary.
- The magnetic switch (2) must be correspondingly affixed onto the transmitter tube (4).

## 8.2 Commissioning of unit if boiler is already in operating condition

- Close drain valve (14) (see sketch chapter 5).
- Slowly open shutoff valve (W) followed by shutoff valve (D).
- Check position of magnetic switch (2) in operating condition and adjust the height if necessary.
- The magnetic switch (2) must be correspondingly affixed onto the transmitter tube (4).

## 9. Operation monitoring



A separate purging of the connection lines including standpipe is demanded for float switches.

### 9.1 Purging of connection lines

- Close shutoff valves (W+D) (see sketch chapter 5).
- Slowly open drain valve (14) and drain water of standpipe.
- Slightly open shutoff valve D and close after approx. 2 seconds.
- Slightly open shutoff valve W and close after approx. 2 seconds.
- Close drain valve (14).
- Slightly open shutoff valves W+D (standpipe is filled now).
- Fully open shutoff valves W+D after the standpipe is filled.

### 9.2 Function test



A function test is prescribed for float switches. Test extend and delays must be specified between operator, boiler manufacturer and local expert.

- Close shutoff valves (W+D) (see sketch chapter 5).
- Slowly open drain valve (14) and drain water.
- The float device sinks now under LWL and the magnetic switch is actuated. The prescribed function test is finished.
- Close drain valve (14).
- Slowly open shutoff valve W and then shutoff valve D.

## 10. Maintenance



Before carrying out maintenance works or a chemical cleaning of the boiler, close shutoff valves of the unit.

Ideally insert blind flanges on the flange connection of the boiler studs. Check state of the unit during boiler revision, especially float (12), float device (11, 12) with transmitter magnet (3), magnetic switch (2) and corresponding shutoff devices.

A deformed float rod impairs the function.

### 10.1 Opening of standpipe



For disassembling, the plant must be pressureless!

Wait until the unit has cooled!

- Close valves (W+D) (see sketch chapter 5).
- Open drain valve (14) and drain unit.
- Caution during disassembly! Residual medium may escape and further evaporation is possible.
- Unfasten bolting (5, 6).
- Remove upper part (7) upwards. Observe that the float rod (11) is not deformed.

### 10.2 Closing of standpipe

- Check sealing surfaces of flanges.
- Mount upper part of the unit with installed float device using a new sealing (8). Observe that the float rod (11) is not deformed.
- Tighten bolting (5, 6) in several steps using successively opposite diagonal tightening until the tightening torque  $Md_{max}$  indicated in the table of chapter 10.4 is reached.
- Carry out commissioning (see chapter 8).

### 10.3 Exchange of float device

- Open standpipe (see chapter 10.1)
- Unfasten transmitter tube cap (9) via retaining spring (10).
- Remove float rod (11) with float (12) from transmitter tube (4) and check.
- Replace deformed or corroded parts.
- Insert complete float device (11, 12) into transmitter tube (4).
- Place transmitter tube cap (9) on transmitter tube (4) and secure with retaining spring (10).
- Close standpipe (see chapter 10.2). Take care that float rod (11) is not deformed!

## 10.4 Tightening torques

All. pressure <b>PS</b> [bar]	Tightening torque Md → <b>Md<sub>max</sub></b> [Nm]					
	in steps					
	1	2	3	4	5	6
32	40	65	90	115	<b>145</b>	-
80	80	110	140	170	195	<b>210</b>

# 11. Drain valve

## 11.1 Construction

<p><b>AV500, AV520</b></p> <ul style="list-style-type: none"> <li>• Male thread G½ on input side</li> <li>• Output side with cutting ring connection ø12 as per DIN 2353 – DS12</li> <li>• Other drain connections on request</li> </ul>	
<p><b>AV580, AV585</b></p> <ul style="list-style-type: none"> <li>• Male thread G½ on input side</li> <li>• Output side with cutting ring connection ø12 as per DIN 2353 – DS12</li> <li>• With limit switch to register the blow-down process</li> <li>• Other drain connections on request</li> </ul>	

- |                             |                           |
|-----------------------------|---------------------------|
| (1) Valve housing           | (11) Handwheel            |
| (2) Sealing ring            | (12) Plate OPEN-CLOSED    |
| (3) Seat                    | (13) Cap nut              |
| (4) Valve spindle with cone | (14) Drain connection     |
| (5) Scraper rings           | (15) Screw                |
| (6) Gland packing           | (16) Switch housing cover |
| (7) Stuffing box            | (17) Limit switch         |
| (8) Screw cap               | (18) Fixing screw         |
| (9) Sealing ring            | (19) Counter nut          |
| (10) Upper part of valve    | (20) Adjusting screw      |



## 11.2 Assembly



Ensure that drain piping has free outlet to atmosphere and is protected from pressure peaks.

- Firmly screw on drain valve with sealing ring (2) on existing unit.
- Cutting ring connection: Assemble drain piping (tube  $\varnothing$  12x1 material St 35.8) on provided drain connection (14) as per DIN 2353 (SW24) (on the part of the builder).  
Welding end: weld on  
Flange: screw on
- Limit switch (15) is already adjusted (factory-made).
- Carry out electrical connection of limit switch.  
Connection cable BIHF 3 x 0,75 or 4 x 0,75.

## 11.3 Commissioning

Rust, sand or similar impurities inside of the medium or during first flushing can cause leakage if they remain in the area of the seat.

### ***Purging of valve:***

- Fully open valve for purging. The pre-pressed packing can lose its denseness due to a longer storage (see chapter 11.4)
- Close valve.

## 11.4 Maintenance



Before carrying out maintenance works on drain valve, unit has to be pressureless and empty!  
Severe burns and scaldings on the whole body are possible!

### ***Re-tightening of gland packing:***

- If a valve is leaky, tighten screw cap (8) with open-end wrench (SW27) clockwise until valve is tight. Spindle (4) has to stay movable.
- Change packing if re-tightening of packing was not successful.

### ***Replacement of packing:***

- Screw off cap nut (13) and remove handwheel (11).
- Unscrew upper part of valve (10).
- Remove screw cap (8) and stuffing box (7).
- Remove spindle with cone (4) upwards.
- Push out gland packing (6) with scraper rings (5) from top and clean packing space.

### **Assembly:**

- Grease spindle thread, insert from top and firmly tighten screws.
- Place new greased packing with scraper rings (5).
- Insert stuffing box (7).
- Tighten screw cap (8).
- Insert new sealing ring (9).
- Grease thread of upper part of valve (10), screw in and tighten with tightening torque  **$M_d = 220 \text{ Nm}$** .
- Place handwheel (11) and tighten cap nut (13).

### **Replacement of complete upper part:**

- For dismounting of component parts see "Replacement of packing"
- Unscrew seat (3) with hexagon socket wrench SW11.
- Grease seat thread, screw in and tighten with tightening torque  **$M_d = 55 \text{ Nm}$** .
- Replace complete upper part.
- Place new spindle.
- For assembly of component parts see above.

### **Replacement of limit switch (17)**



Switch off mains voltage for limit switch (17)!

- Unfix screws (15) and remove switch housing cover (16).
- Disconnect electrical connection from limit switch. Unfasten fixing terminals and unscrew sealing ring of cable gland.
- Unfix counter nut (19) and turn back adjusting screw (20).
- Unfasten fixing screws (18).
- Replace limit switch and fasten again.
- Carry out electrical connection and close housing again.
- Close drain valve.
- Quick action contact of limit switch must react after approx. 2 turns of the handwheel (open valve). Contact position (13, 14-breaker) changes to (21,22-maker) (see fig. "contact position").  
Readjustment with adjusting screw (20).
- Tighten counter nut (19) and fixing screws (18) after adjustment.
- Close drain valve!

Contact position (open):

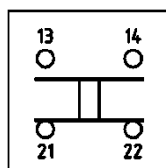

## 13. Spare parts

Always indicate article no. and serial no. (indicated on the identification plate) in case of spare parts order!

### 13.1 Float switch

Pos. no.	Designation	PS [bar]	Article no.	Quantity
2	Magnetic switch	32-80	15-01122	Depending on order
17	O-Ring		40-00301	1
18	O-Ring		40-00300	1
19	O-Ring		40-00309	1
20	Float device		15-000006	1
12	Float		40-00918	1
5	Thread bolt	32	40-01501	8
8	Sealing		40-00193	1
6	Hex nut		40-01500	16
5	Thread bolt	50 <sup>1)</sup>	40-00381	4
8	Sealing		40-00189	1
6	Hex nut		40-00723	8
5	Bolt	80	40-00414	8
8	Serrated gasket		40-00200	1
6	Hex nut		40-00737	16

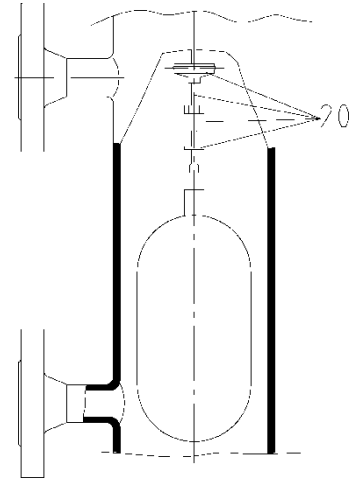

1) version square flange

### 13.2 Drain valve

Pos. no.	Designation	Article no.																							
		AV500	AV520	AV585	AV580																				
2	Sealing ring (threaded pipe G1/2)	40-00099																							
9	Sealing ring	40-02008																							
5	Scraper rings																								
6	Gland packing																								
3	Seat	40-01863	40-01864	40-01863	40-01864																				
9	Sealing ring	40-02033																							
4	Spindle with rolled cone					40-02034																			
9	Sealing ring									40-02005															
10	Upper part of valve													40-02036											
5	Scraper rings																	40-02037							
6	Gland packing																					40-02036			
7	Stuffing box																								
8	Screw cap	40-02037																							
11	Handwheel					40-02036																			
12	OPEN/CLOSED plate									40-02037															
13	Cap nut													40-02036											

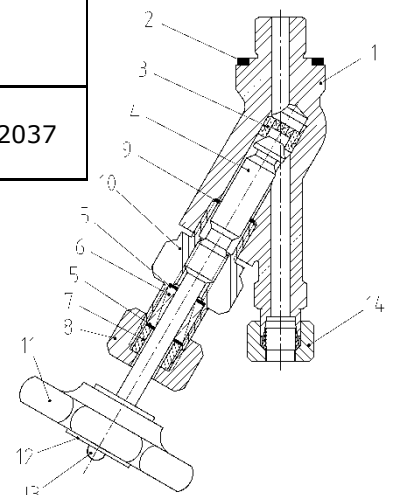

## 14. Decommissioning



Severe burns and scaldings on the whole body are possible!

Before detaching flange connections, screws of stuffing box etc., all connected lines must be pressureless (0 bar) and cooled off to ambient temperature (20°C)!

### 14.1 Disposal

Dismount unit and separate waste products.

When disposing the unit, observe legal regulations for waste disposal.

## 15. Declaration of Conformity



### Declaration of Conformity

Declaration of Conformity in accordance with the  
PED-Directive 2014/68/EU

The Company:  
IGEMA GmbH  
Antwerpener Str. 1  
48163 Münster  
Germany

declares as manufacturer, that the product:

„float switch“ with the function LWL limiter  
as pressure holding part with safety function

Product type:

RBA 24 / 34  
BA 14

complies with the Directive  
and that the following Conformity Assurance System was used:

Category IV, Modules B+D

Applicable standards:

EN 12952  
EN 12953

notified body for module B:	notified body for module D
Dekra Automobil GmbH	TÜV Rheinland Industrieservice GmbH
Handwerkstraße 15	Am Grauen Stein
D-70585 Stuttgart	D-51105 Cologne
Germany	Germany
Identification number 2266	Identification number 0035

Münster, . . .

Dipl. Ing. J. Barlage (SFI / EWE)  
Inspection Officer

## 16. Supplement

### Warranty

We accord a warranty period of 24 month on our products. A condition for that is the appropriate treatment according to these mounting and operating instructions. The warranty for wear and spare parts is restricted to material defects and construction faults.

The magnetic switches installed in the float switches are wear parts and are **not** included in the warranty.

The sealings/gland packing installed in the valves are **not** included in the warranty.

**IGEMA GmbH  
Antwerpener Str. 1  
D-48163  
Germany**

**Fon.: +49 25 01 9 24 24 0  
Fax.: +49 25 01 9 24 24 99**

**info@igema.com  
www.igema.com**



This high-quality IGEMA product was designed, manufactured and tested with the application of the QM System guidelines in accordance with DIN EN ISO 9001:2000.

If the device supplied indicates transport damage or gives cause for complaint in spite of our final quality control please contact our SERVICE department on telephone 0241- 5687-0 by return.